

# Fundamentals of Business Process Management

Marlon Dumas, Marcello La Rosa, Jan Mendling, Hajo A. Reijers

April 24, 2013

## Errata

### Chapter 4

1. Figure 4.15: The sequence flow labels “already registered” and “not yet registered” should be swapped. The updated figure is provided below.

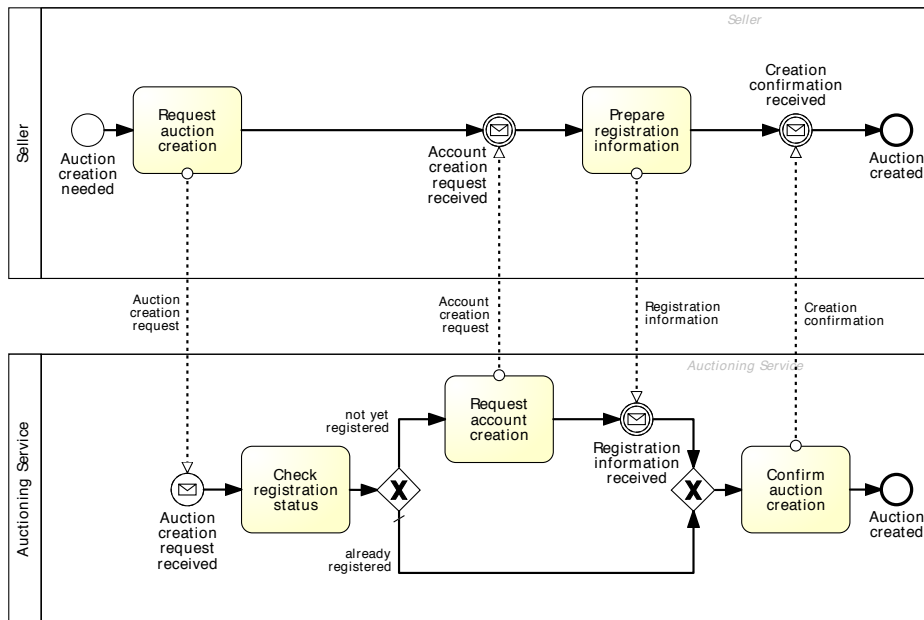

Figure 4.15

## Chapter 5

1. Page 172, first paragraph: “This is the case when the *soundness* property holds (see Chap. 3). Common sound and unsound process fragments...” Replace this sentence with the text below.

“A *deadlock*, as shown in Chap. 3, occurs when a running process instance is not able to progress any further once a given state is reached, i.e. a token gets stuck at that state. A *livelock* occurs when a process instance keeps cycling in a loop, i.e. a token is free to move but only within the loop. Both deadlocks and livelocks prevent tokens from reaching an end event, so the process instance may not be able to complete altogether. Another behavioral anomaly is the *lack of synchronization*, occurring when two or more tokens running in parallel are not synchronized at some join gateway, with the result that an end event may be reached multiple times (once per token). Finally, a *dead activity* is an activity that can never be executed in any instance of the process model.

In the light of above, we say that a process model is behaviorally correct, or *sound*, if and only if it satisfies the following requirements:

- (a) *option to complete*: any running process instance must eventually complete, i.e. there are no deadlocks or livelocks,
- (b) *proper completion*: at the moment of completion, each token of the process instance should be in a different end event, i.e. there is no lack of synchronization, and
- (c) *no dead activities*: any activity can be executed in at least one process instance.

The above definition of *soundness* only takes into account the control-flow of a process model, assuming all input data objects and incoming messages are available when an activity is to be executed, and that all output data objects and outgoing messages are produced upon an activity’s completion.

Common sound and unsound process fragments...”

2. Page 173, last paragraph: “There are two essential aspects of semantic quality: validity and completeness indexCompleteness.” should read “There are two essential aspects of semantic quality: validity and completeness.”

3. Exercise 5.18: The text for this exercise should be only “Have a look at the process model of Fig. 5.10 showing a sales campaign process for one of our industry partners. Describe which 7PMG guidelines can be used to improve this model.”
4. Exercise 5.19: The text of Exercise 5.19 is wrongly merged into 5.18. Exercise 5.19 should read “Have a look at the process model of Figure ?? showing a sales campaign process for one of our industry partners. Describe which 7PMG guidelines can be used to improve this model.”

## Chapter 7

2. Page 224, first paragraph: “However, if the upper branch is taken only 10% of the times and the lower branch is taken 90% of the times, ...” should be “However, if the lower branch is taken only 10% of the times and the upper branch is taken 90% of the times, ...”
3. Page 224, again first paragraph: “Thus, if the upper branch has a frequency of 10% and the lower branch a frequency of 90%, ...” should be “Thus, if the lower branch has a frequency of 10% and the upper branch a frequency of 90%, ...”
4. Figure 7.5: Probabilities  $p_1$ ,  $p_2$  and  $p_n$  should not appear in this figure.
5. Table 7.2: The heading of the right-hand column should be “Processing time”, not “Cycle time”.
6. Exercise 7.3: “...ministerial enquiry process introduced in Exercise 3.7 (page 78).” should be “...ministerial enquiry process introduced in Example 3.7 (page 78).”
7. Example 7.6: “On average, 0.05 orders are received per day ( $\lambda = 0.05$ ), and 0.2 orders are fulfilled per day ( $\mu = 0.1$ ).” should be “On average, 0.05 orders are received per day ( $\lambda = 0.05$ ), and 0.1 orders are fulfilled per day ( $\mu = 0.1$ ).”

## Chapter 9

8. Figure 9.6: the condition labels “in stock” and “not in stock” should be swapped. The labels on the message flows emanating from pools Supplier 1

and Supplier 2 should be “Raw materials”. The updated figure is provided below.

9. Figure 9.10: An improved version of this figure is provided below, where the borders of the boxes are thicker.

## **Chapter 10**

10. In the  $\alpha$ -Algorithm, step 5.b) must read: Eliminating  $b \rightarrow d$  and  $c \rightarrow d$  if there exists some  $(b\#c) \rightarrow d$ .

## **Index**

11. Y: “Yet Another Workflow System” should be “Yet Another Workflow Language”.

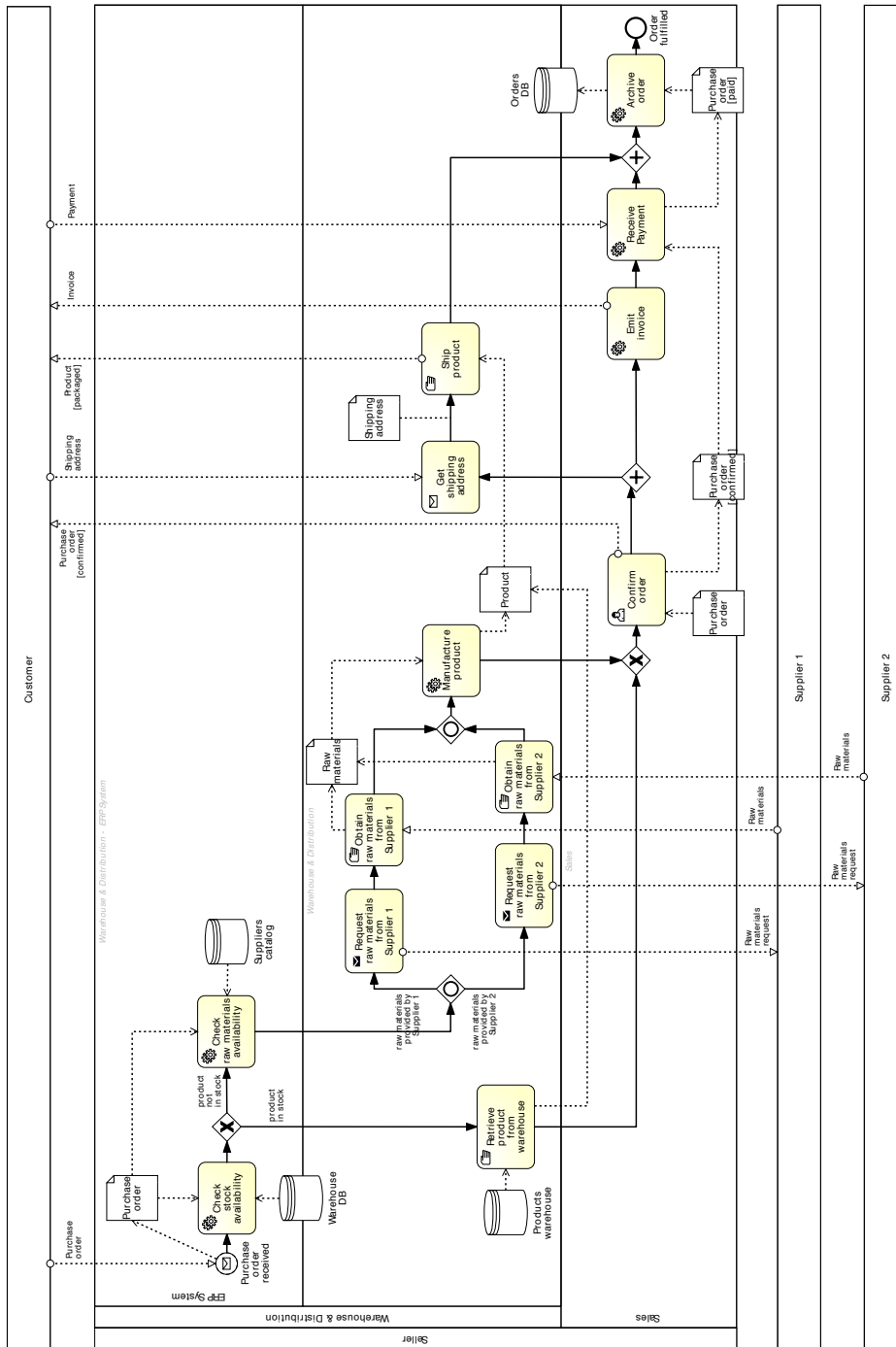

Figure 9.6

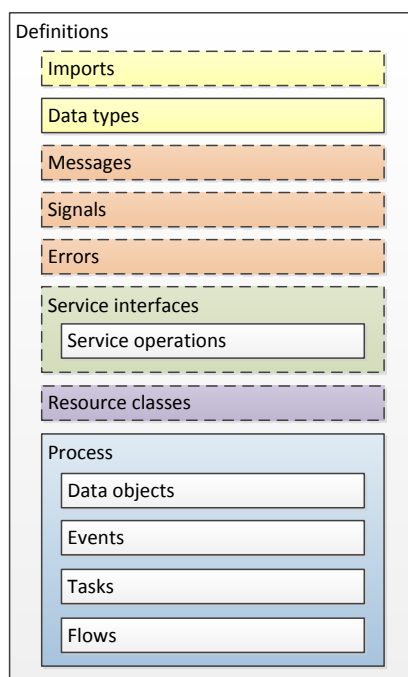

Figure 9.10